

GL102 Intelligent Temperature Controller

User's Guide



1 Caution

Abnormal operating conditions can lead to one or more undesirable events that, in turn, could lead to injury to personnel or damage to the equipment or other property. Do not touch the AC terminals while the power is supplied to the controller to prevent an electric shock. Make sure power is disconnected while checking the unit inside. To minimize the risk of potential safety problems, you should follow all applicable local and national codes that regulate the installation and operation of your equipment.

2 Features

- Compact size, only 48x48x75mm.
- RTD input (PT100, CU50) or Thermocouple input (T, R, J, B, S, K, E, WRe3-WRe25).
- Display the temperature in Celsius or Fahrenheit.
- Universal controller to work with either SSR or mechanical relay.
- Set control mode to PID or on/off, for either SSR or mechanical relay.
- When set the main control to SSR output, the internal relay J1, J2 can be set for alarm. When set the main control to J2 relay, then J1 relay can be set for alarm.

3 Specifications

- Power supply: AC/DC85~260V (50Hz/60Hz).
- J1 relay contact capacity: AC250V/3A.
- Relay contact life: 1×10^5 .
- SSR control signal: 12V (open-circuit voltage), 30mA (short-circuit current).
- Temperature accuracy: 0.2%FS.
- Dimensions: 48x48x75mm.
- Mounting panel cutout: 45x45mm

4 Back terminals

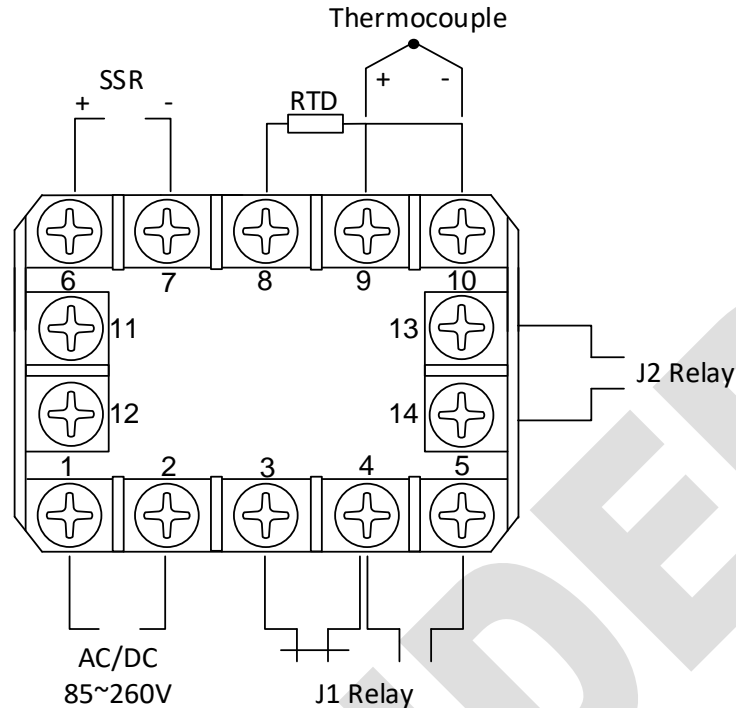

Figure 1 Back Terminals Wiring Diagram

4.1 Sensor connection

The default setting for the input type is for K type thermocouple, for different probe type, the parameter **Inty** in [Table 1](#).

For thermocouple, connect the positive wire to terminal 9 and the negative wire to terminal 10. For K type thermocouple, if the wires are red and yellow, the yellow wire is positive. If they are red and other color (blue, white, green...), the red is positive. If the polarity is reversed, when the temperature goes higher, the readout will decrease.

For three-wire PT100 probe, if the wire color code is red, red and white (to IEC60751), connect the two red wires to terminals 9 and 10 respectively, and connect the white wire to terminal 8. For two-wire PT100 probe, connect one wire to terminal 8 and connect the other wire to terminal 9, and short the terminals 9 and 10. The parameter **Inty** need to be changed to P10.0 (for 0.1 degree display resolution) or P100 (for 1 degree display resolution).

4.2 SSR connection

When the main control output is set to SSR (**Outy** in [Table 1](#) is set to 2 or 3), the SSR output is enabled. The terminal 6 should be connected to the positive pole of the DC control side of the SSR, the terminal 7 should go to the negative pole of the SSR. When there is no SSR connected to the terminals 6 and 7, there should be around 8V DC between them when the **OUT** indicator is on.

4.3 J1, J2 relay connection

J2 relay can be set to PID or on/off control output, or set as an alarm relay (see **Outy** in [Table 1](#)). J1 is for alarm only. Please note the relays are just a switch, there is no power on them. The power need to be provided to the load connected to the relays.

4.4 Power to the controller

The controller can be powered by AC/DC from 85 to 260V. The ground power line is not necessary. For DC power, the polarity does not matter.

5 Front Panel

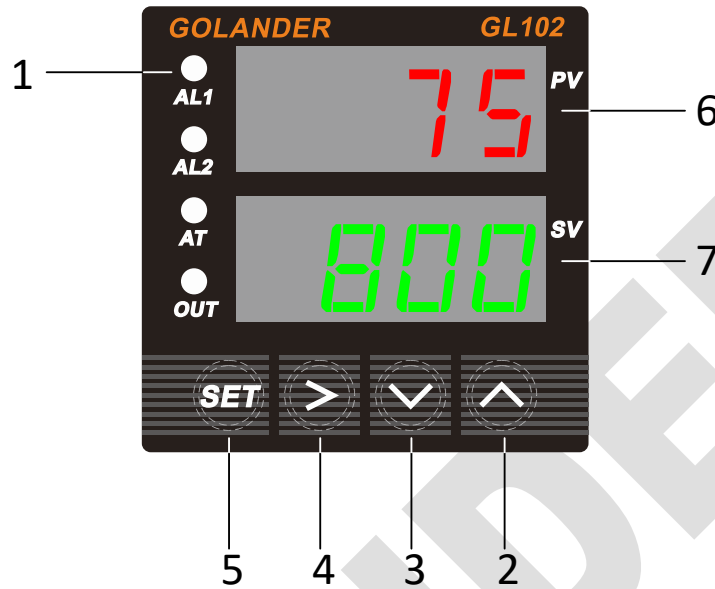

Figure 2 Front Panel

1 – Indicators

AL1: relay J1 output indicator. On when J1 relay closed

AL2: relay J2 output indicator. On when J2 relay closed

AT: Auto tune indicator. Flashing during auto tune. On when in [Manual Control Mode](#)

OUT: SSR control output indicator.

2 – Up key, select next parameter or increase value

3 – Down key, select previous parameter or decrease value

4 – Shift Key, Shift the digit when changing the setting, or press and hold the key to start auto tune

5 – SET key, parameter set/confirm

6 – PV, measured value display

7 – SV, target temperature display

6 Initial function parameters (input passcode 0089 after pressing the SET key)

Table 1

Symbol	Name	Description	Range	Factory Value	Mark
<i>Inty</i>	Inty	Input type	See Table 2	K	Note 1
<i>Outy</i>	Outy	Control output type	0, 1, 2, 3, 4	2	Note 2
<i>Hy</i>	Hy	Hysteresis Band	0~9999	3	Note 3
<i>Psb</i>	Psb	Display temperature offset	-100~100 (degrees)	0	Note 4
<i>rd</i>	rd	Control action type	0: heat; 1: cool	0	
<i>CorF</i>	CorF	Display Unit selection	0: ° C; 1: ° F	1	
<i>End</i>	END	Exit			

To access the **0089** menu, press and hold the **SET** key, the display will show 0000, use the **UP/DOWN** key to change the value to 0089. Press **SET** key, the display will change to be *Inty*. Press **UP/DOWN** key to change the display to other parameters, or press **SET** key again to modify the value for *Inty*, then press **SET** key to confirm the change. When changing the value, user can use the > key to shift the digit. Use the same operation to access the [SV and alarm parameters](#) (input passcode 0001 after pressing the **SET** key) and [PID parameters](#) (input passcode 0036 after pressing the **SET** key) menu.

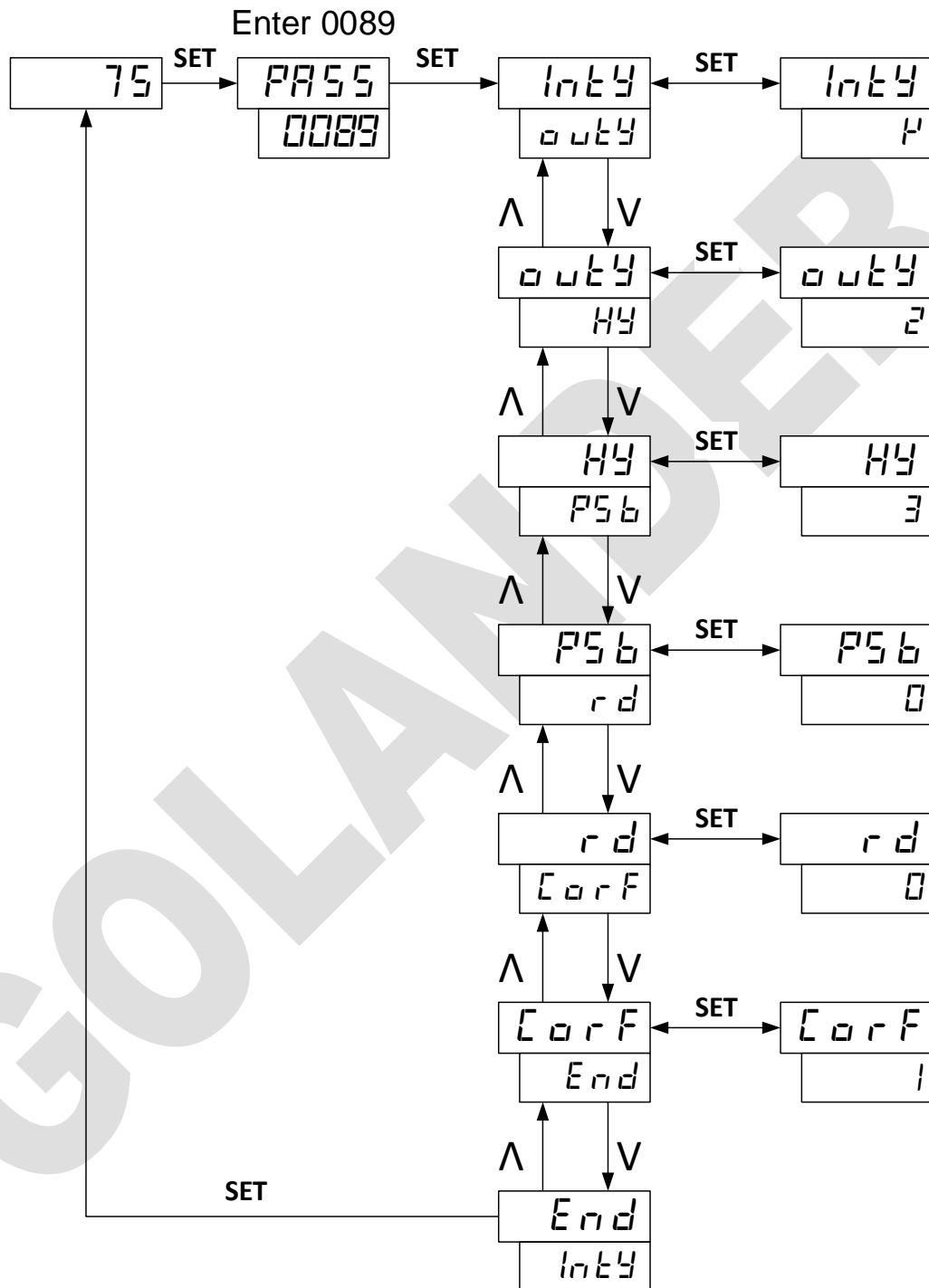

Figure 3. Initial function parameters setup

Note 1. The default setting for the input probe type is K type thermocouple. If not, please change the **Inty** to the one of the input type shown in the [Table 2](#).

Table 2

Symbol	Name	Sensor Type	Temperature Range	Note
T	T	T type thermocouple	-200~400 °C; -320~752°F	Internal resistance 100Kohms
R	R	R type thermocouple	-50~1600 °C; -58~2900 °F	
J	J	J type thermocouple	-200~1200°C; -320~2200 °F	
WRE	WRE	Wre type thermocouple	0~2300 °C; 32~4200 °F	
B	B	B type thermocouple	350~1800 °C; 660~3300 °F	
S	S	S type thermocouple	-50~1600 °C; -58~2900 °F	
K	K	K type thermocouple	-200~1300 °C; -320~2372 °F	
E	E	E type thermocouple	-200~900 °C; -320~1650 °F	Constant current output 0.2mA
P10.0	P10.0	PT100 RTD, 0.1° resolution	-99.9~600.0 °C; -99.9~999.9 °F	
P100	P100	PT100 RTD, 1° resolution	-200~600 °C; -320~1100 °F	
Cu50	Cu50	CU50 RTD	-50.0~150.0 °C; -60~300 °F	

Note 2. Outy - Control output type

- 0: Set J1, J2 relays as alarm output, SSR output disabled.
- 1: Set J1 relay as alarm output, J2 relay as PID control output, SSR output disabled. SV is the control temperature.
- 2: Set J1, J2 relays as alarm output, set SSR as PID control output. SV is the control temperature.
- 3: Set J1, J2 relays as alarm output, set SSR as on/off control output. SV is the control temperature.
- 4: Set J1 relay as alarm output, set J2 relay as on/off control output. SSR output disabled.

Note 3. Hy - Hysteresis Band

The parameter **Hy** is only for on/off control. For heating control mode, when the measured temperature PV reaches the target temperature **SV**, the control output will be off; when PV drops down to **SV-Hy**, the control output will be on again. For cooling control mode, when PV drops down to SV, the control output will be off, when PV increases to **SV+Hy**, the control output will be on again.

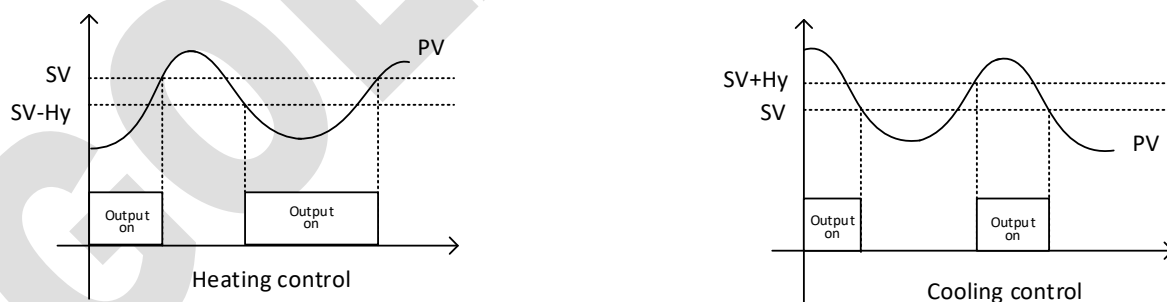

Figure 4. on/off control

Note 4. Psb - Display temperature offset

This feature allows the input value to be changed to agree with an external reference or to compensate for sensor error. For example, if the measured temperature of the controller is 100 degrees, but the reference temperature is 98 degrees. By setting the **Psb**= -2, the PV display of the controller would change to be 98. To set the negative value for **Psb**, use the shift key to move the focus digit to the first digit from the left, and then use the down key to change the digit to show the negative symbol.

7 PID parameters (input passcode 0036 after pressing the SET key)

Table 3

Symbol	Name	Description	Range	Factory value	Mark
<i>P</i>	P	Proportional band	0.1~99.9%	5.0	Note 5
<i>I</i>	I	Integral time	2~1999 Seconds	100	Note 6
<i>d</i>	d	Derivative time	0~399 Seconds	20	Note 7
<i>SouF</i>	SouF	Overshoot suppression factor	0.0~1.0	0.2	Note 8
<i>ot</i>	ot	Proportional cycle	2~199 seconds	2	Note 9
<i>FILT</i>	FILT	Digital filter factor	0~3	0	Note 10
<i>End</i>	END	Exit			

Note 5. P – Proportional band

The proportional term produces an output value that is proportional to the current error value. A high proportional gain results in a large change in the output for a given change in the error. If the proportional gain is too high, the system can become unstable. In contrast, a small gain results in a small output response to a large input error, and a less responsive or less sensitive controller. If the proportional gain is too low, the control action may be too small when responding to system disturbances. In a real system, proportional-only control will leave an offset error in the final steady-state condition. Integral action is required to eliminate this error.

Note 6. I – Integral time

The contribution from the integral term is proportional to both the magnitude of the error and the duration of the error. The integral in a PID controller is the sum of the instantaneous error over time and gives the accumulated offset that should have been corrected previously. The accumulated error is then multiplied by the integral gain and added to the controller output. The integral term accelerates the movement of the process towards set point and eliminates the residual steady-state error that occurs with a pure proportional controller. However, since the integral term responds to accumulated errors from the past, it can cause the present value to overshoot the set point value.

Note 7. d – Derivation time

The derivative of the process error is calculated by determining the slope of the error over time and multiplying this rate of change by the derivative gain. The magnitude of the contribution of the derivative term to the overall control action is termed the derivative gain. Derivative action predicts system behavior and thus improves settling time and stability of the system. An ideal derivative is not causal, so that implementations of PID controllers include an additional low pass filtering for the derivative term, to limit the high frequency gain and noise. Normally **d** is set to 25% of the I value.

Note 8. SouF – Overshoot suppression factor

Overshooting and undershooting are restricted by the **SouF** and increase of the parameter can suppress the overshooting

Note 9. Proportional cycle

It's the cycle time to switch the output on/off. Within the cycle t time, the output will turn on and off once. For SSR, in general the cycle time is set to 2 seconds. For mechanical relays, set the cycle time to a higher value to save the life time of the relay.

Note 10. Filt – digital filter factor

The filter is to increase the measured temperature display stability, but will delay the response. When **Filt** is set to 0, the filter is disabled. 1, 2 and 3 are weak, medium and strong, respectively.

8 Auto tune

For PID control mode, if the control with default **P**, **I** and **d** parameters settings are not able to hold the target temperature, the built-in auto tune function can find the right PID parameters for the system. When on heating mode, it will heat up the system to the target temperature then let the system cool down. It will repeat this process for about 3 times, then the controller will calculate the parameters automatically.

To activate the auto tune function, press and hold the **>** key until the “**AT**” indicator starts to blink. When auto tune process finished, the “**AT**” indicator will stop blinking. The new values for parameters **P**, **I** and **d** are calculated by the controller.

To stop the auto-tuning, press and hold **>** key for 3 seconds, until “**AT**” indicator stops blinking. The PID parameters values will not change.

Please note:

- Auto tune from time to time, there will be a significant temperature overshoot, please lower SV value to prevent accident.
- The sensor, load (heater...) need to be connected properly, otherwise, the auto tune will not complete.
- The time for the auto tune depends on the system response time, would be from a few minutes to hours.
- Only need to run auto tune one time.

9 SV and alarm parameters (input passcode 0001 after pressing the SET key)

Table 4.

Symbol	Name	Description	Factory value	Mark
<i>Sv</i>	SV	Target temperature (Set Value)	80	Note 11
<i>AH1</i>	AH1	Alarm (J1 relay) on temperature	800	Note 12
<i>AL1</i>	AL1	Alarm (J1 relay) off temperature	900	
<i>AH2</i>	AH2	Alarm (J1 relay) on temperature	800	
<i>AL2</i>	AL2	Alarm (J1 relay) off temperature	900	
<i>End</i>	END	Exit		

Note 11. The **SV** value can be set by accessing the 0001 menu. Or, when in normal operation mode, use the **UP** or **DOWN** key to change the **SV** directly.

Note 12. When the J1 (J2) relays are set as alarm, the relay will be controlled by the two parameters **AH1** (**AH2**) and **AL1** (**AL2**). The alarm can be set as high alarm or low alarm.

For high alarm, set **AH1** (**AH2**) > **AL1** (**AL2**). When the temperature increase to **AH1** (**AH2**), the J1 (J2) relay will be closed (alarm on), when the temperature drops down to **AL1** (**AL2**), the J1 (J2) relay will be open (alarm off).

For low alarm, set **AH1** (**AH2**) < **AL1** (**AL2**). When the temperature decrease to **AH1** (**AH2**), the J1 (J2) relay will be closed (alarm on), when the temperature increases to **AL1** (**AL2**), the J1 (J2) relay will be open (alarm off).

10 Manual Control Mode

User can switch the control mode from PID mode to manual mode. Manual mode allows user to adjust the output percentage manually. The output will remain the set percentage regardless what the measured temperature is. For example, if the cycle time is 2 seconds, output percentage is set to 75, then in every 2 seconds, the output will be on for 1.5 seconds and will be off for 0.5 seconds. To switch from PID mode to manual mode, press and hold the **SET** key until the AT indicator turns on. The PV window of the controller will still show the measured temperature, the first digit of the SV window will show a letter "M", which means the controller is on manual mode. The right 3 digits of the SV window will show the output percentage. User can use the **UP/DOWN** key to change the percentage manually. To switch back to PID mode, press and hold the **SET** key until the **AT** indicator turns off.

11 Examples

11.1 Control a 110V AC Solenoid Valve

Use J2 relay to control the valve directly.

- 1) To use PID mode to control the valve, set outy=1, set cycle time ot=15 seconds to save the lifetime of the J2 relay and the valve. Set the SV to the desired temperature you want to hold, for example, SV=350°F.
- 2) To keep the temperature in a range, for example, 345-350°F, set the output control to on/off mode, outy=4; keep the cycle time setting ot=2. Set SV=350, Hy=5. The output will be off when temperature goes above 350°F, and will be on again when temperature drops down to SV-Hy=345°F.

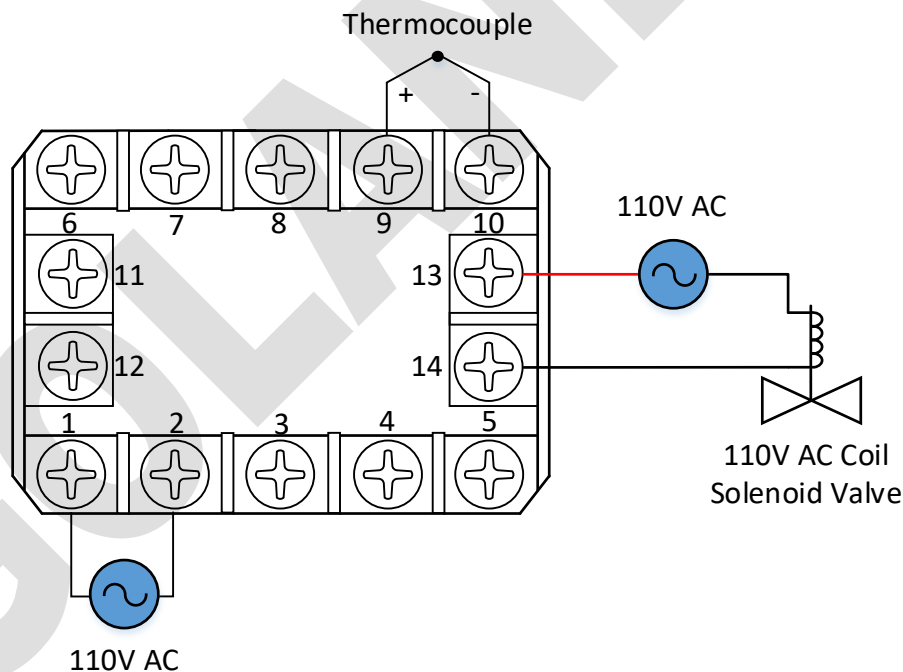

Figure 5. 110V AC Solenoid Valve Wiring

Note: For 220V AC solenoid valve, change the power source to 220V AC, use hot line 1 (L1) and hot line 2 (L2) to power the controller and the valve.

11.2 Control a 110V Heater via SSR

To use a PT100 probe and a heater to keep the temperature to 200°F, keep the output setting for PID control mode, outy=2; set input type for PT100, Inty=P10.0; set target temperature SV=200.

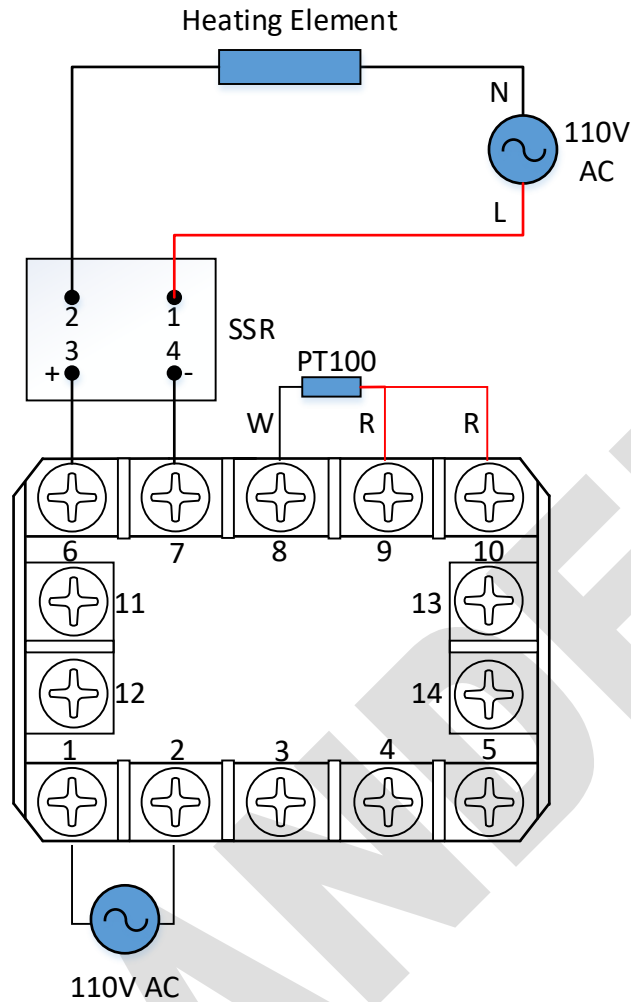

Figure 6. Heater Wiring

Note: For 220V AC heater, change the power source to 220V AC, use hot line 1 (L1) and hot line 2 (L2) to power the controller and the heater.

11.3 Control a 220V AC Heater via Contactor

If heater draws more than 3A, the J2 relay could not handle it directly. A 220V coil contactor can be used to power the heater.

- 1) To use PID mode to control the heater, set outy=1, set cycle time ot=15 seconds to save the lifetime of the J2 relay and contactor. Set the SV to the desired temperature you want to hold, for example, SV=350°F.
- 2) To keep the temperature in a range, for example, 330-350°F, set the output control to on/off mode, outy=4; keep the cycle time setting ot=2. Set SV=350, Hy=20. The output will be off when temperature goes above 350°F, and will be on again when temperature drops down to SV-Hy=320 °F.

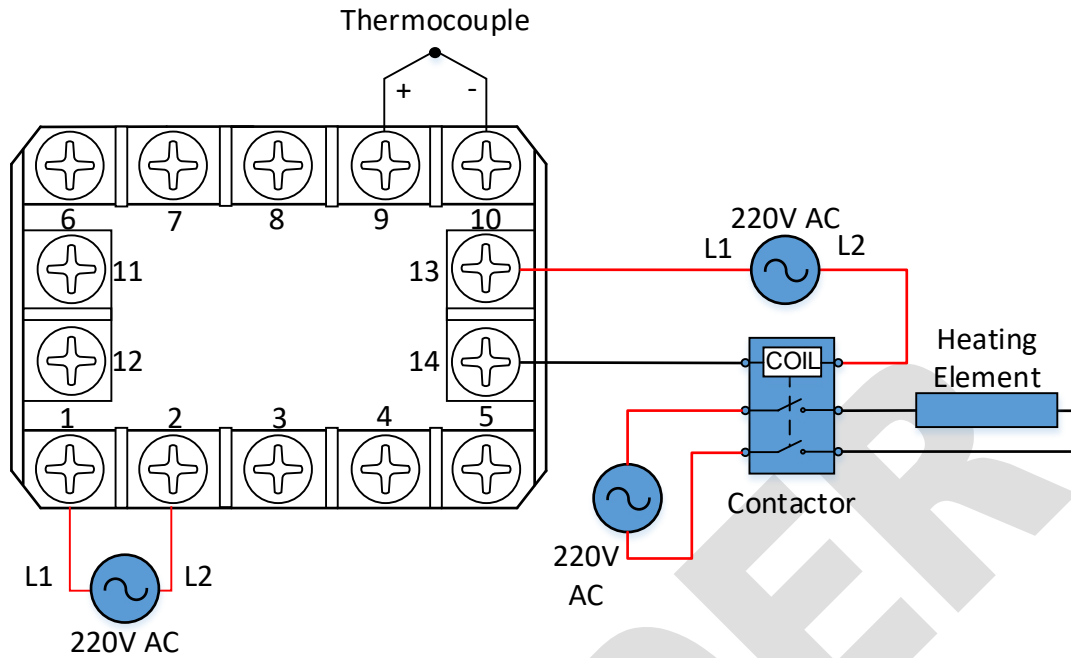

Figure 7. Use Contactor for Heater

11.4 Use J1 Relay to Trigger an 110V Alarm Buzzer

J1 relay is controlled by parameters AH1 and AL2.

- 1) High alarm: If you want the buzzer to be on when temperature is higher than 210°F, and to be off when temperature drops down to 205°F, set AH1=210, AL1=205 (AH>AL).
- 2) Low alarm: If you want the buzzer to be on when temperature is lower than 5°F, and to be off when temperature goes back to 10°F, set AH1=5, AL1=10 (AH<AL).
- 3) When the J2 relay is set to alarm (Outy=0, 2 or 3), the setting is similar to J1 relay.

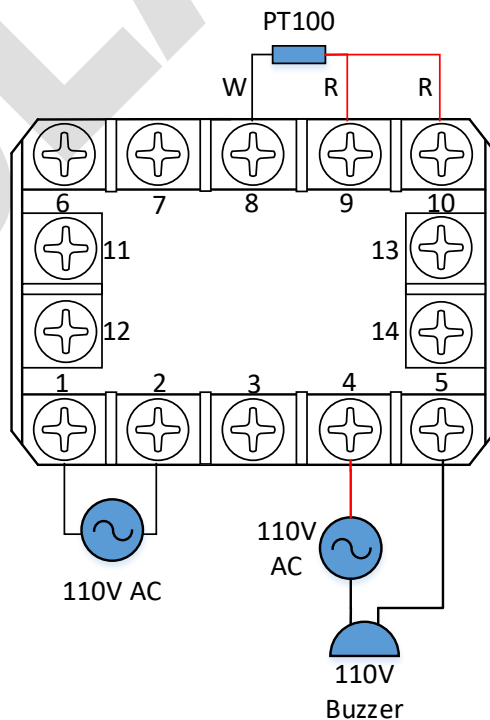

Figure 8. Use J1 Relay for Alarm

12 Quick Guide

First, set the parameter **Inty** to the sensor type connected to the controller if it is not a K type thermocouple, set the parameter **Outy** for the output control mode. For controlling a mechanical relay in PID mode, change the cycle time **ot** to 5~60 seconds to save the lifetime of the relay. Then you are ready to go. For PID mode, if the system is not able to hold the temperature, run [*Auto tune*](#). Set the alarm parameters **AH**, **AL** if needed.

If the controller displays EEEE, that means something wrong with the input or with the setting of the input. Please check the sensor connection and the **Inty** parameter setting. Questions? Please contact us.

Golander LLC

<http://golanderusa.com>

email: info@golanderusa.com

GOLANDER