

# GL101B Intelligent Temperature Controller User's Guide



## 1 Caution

Abnormal operating conditions can lead to one or more undesirable events that, in turn, could lead to injury to personnel or damage to the equipment or other property. Do not touch the AC terminals while the power is supplied to the controller to prevent an electric shock. Make sure power is disconnected while checking the unit inside. To minimize the risk of potential safety problems, you should follow all applicable local and national codes that regulate the installation and operation of your equipment.

## 2 Features

- Compact size, only 24x48x75mm.
- RTD input (PT100, CU50) or Thermocouple input (T, R, J, B, S, K, E, WRe3-WRe25).
- Display the temperature in Celsius or Fahrenheit.
- Universal controller to work with either SSR or mechanical relay (contactor).
- Set control mode to PID or on/off, for either SSR or mechanical relay (contactor).
- When set the main control to SSR output, the internal relay J1 can be set for alarm.

## 3 Specifications

- Power supply: 9-30V DC.
- J1 relay contact capacity: AC250V/3A.
- Relay contact life:  $1 \times 10^5$ .
- SSR control signal: 12V (open-circuit voltage), 30mA (short-circuit current).

- Temperature accuracy: 0.2%FS.
- Dimensions: 48x24x75mm.
- Mounting panel cutout: 45x22mm

## 4 Back terminals

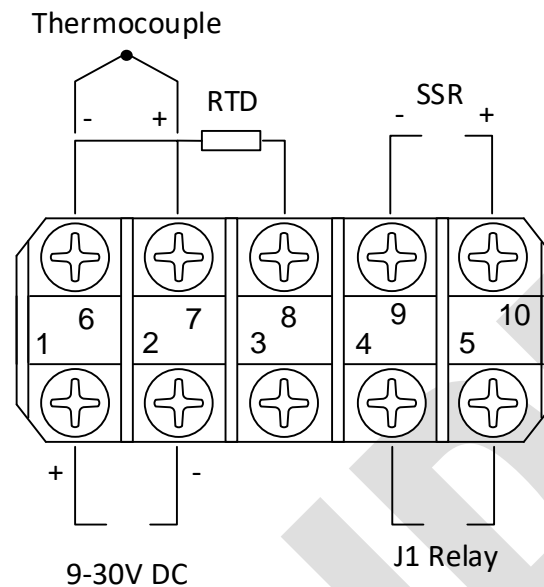

Figure 1 Back Terminals Wiring Diagram

### 4.1 Sensor connection

The default setting for the input type is for K type thermocouple, for different probe type, the parameter **Inty** in [Table 1](#) need to be changed.

For thermocouple, connect the positive wire to terminal 7 and the negative wire to terminal 6. For K type thermocouple, if the wires are red and yellow, the yellow wire is positive. If they are red and other color (blue, white, green....), the red is positive. If the polarity is reversed, when the temperature goes higher, the readout will decrease.

For three-wire PT100 probe, if the wire color code is red, red and white (to IEC60751), connect the two red wires to terminals 6 and 7 respectively, and connect the white wire to terminal 8. For two-wire PT100 probe, connect one wire to terminal 7 and connect the other wire to terminal 8, and short the terminals 6 and 7. The parameter **Inty** need to be changed to P10.0 (for 0.1 degree display resolution) or P100 (for 1 degree display resolution).

### 4.2 SSR connection

When the main control output is set to SSR (**OUTY** in [Table 1](#) is set to 2 or 3), the SSR output is enabled. The terminal 10 should be connected to the positive pole of the DC control side of the SSR, the terminal 9 should go to the negative pole of the SSR. When there is no SSR connected to the terminals 9 and 10, there should be around 12V DC between them when the **OUT** indicator is on.

### 4.3 J1 relay connection

J1 relay can be set to PID or on/off control output, or can be used as an alarm relay (see **OUTY** in [Table 1](#)). Please note the J1 relay is just a switch, there is no power on it. The power need to be provided to the load connected to the terminal 4 and 5.

#### 4.4 Power to the controller

The controller can be powered by 9-30V DC. Terminal 1 is for positive and terminal 2 is for negative. The ground power line is not necessary.

### 5 Front Panel

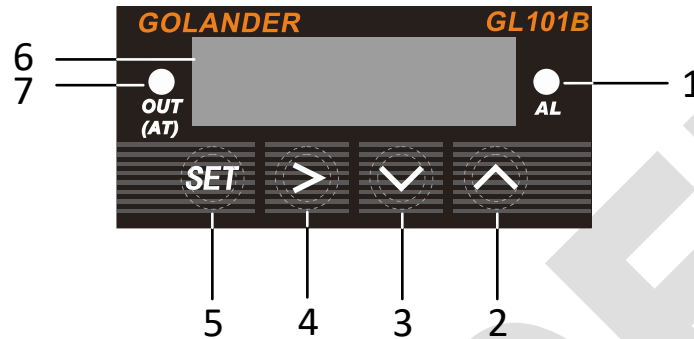

Figure 2 Front Panel

- 1 – AL indicator, relay J1 output indicator
- 2 – Up key, select next parameter or increase value
- 3 – Down key, select previous parameter or decrease value
- 4 – Shift Key, Shift the digit when changing the setting, or press and hold the key to start [Auto tune](#).
- 5 – SET key, parameter set/confirm
- 6 – Measured value (PV) display
- 7 – SSR control output indicator/auto tune indicator

### 6 Initial function parameters (input passcode 0089 after pressing the SET key)

Table 1

Symbol	Name	Description	Range	Factory Value	Mark
<i>Inty</i>	Inty	Input type	See <a href="#">Table 2</a>	K	<a href="#">Note 1</a>
<i>Outy</i>	Outy	Control output mode	0, 1, 2, 3, 4	2	<a href="#">Note 2</a>
<i>Hy</i>	Hy	Hysteresis Band	0~9999	3	<a href="#">Note 3</a>
<i>PSb</i>	PSb	Display temperature offset	-100~100 (degrees)	0	<a href="#">Note 4</a>
<i>rd</i>	rd	Control action type	0: heat; 1: cool	0	
<i>CorF</i>	CorF	Display Unit selection	0: °C; 1: °F	1	
<i>End</i>	END	Exit			

**To access the 0089 menu**, press and hold the **SET** key, the display will show 0000, use the **UP/DOWN** key to change the value to 0089. Press **SET** key, the display will change to be *Inty*. Press **UP/DOWN** key to change the display to other parameters, or press **SET** key again to modify the value for *Inty*, then press **SET** key to confirm the change. When changing the value, user can use the > key to shift the digit. Use the same operation to access the [SV and alarm parameters](#) (input passcode 0001 after pressing the **SET** key) and [PID parameters](#) (input passcode 0036 after pressing the **SET** key) menu.

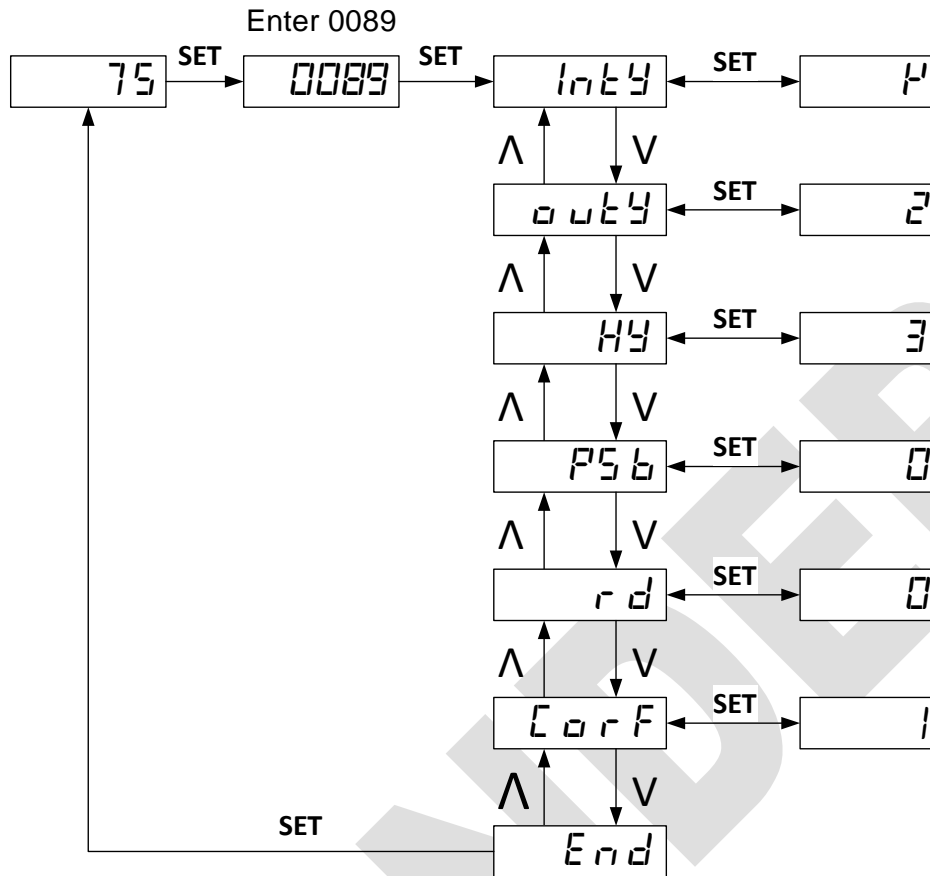

Figure 3. Initial function parameters setup

**Note 1.** The default setting for the input probe type is K type thermocouple. If the probe is not K, please change the **Inty** to the one of the input type shown in [Table 2](#).

Table 2

Symbol	Name	Sensor Type	Temperature Range	Note
T	T	T type thermocouple	-200~400 °C; -320~752°F	Internal resistance 100Kohms
R	R	R type thermocouple	-50~1600 °C; -58~2900 °F	
J	J	J type thermocouple	-200~1200°C; -320~2200 °F	
WRE	WRE	Wre type thermocouple	0~2300 °C; 32~4200 °F	
B	B	B type thermocouple	350~1800 °C; 660~3300 °F	
S	S	S type thermocouple	50~1600 °C; -58~2900 °F	
K	K	K type thermocouple	-200~1300 °C; -320~2400 °F	
E	E	E type thermocouple	-200~900 °C; -320~1650 °F	Constant current output 0.2mA
P10.0	P10.0	PT100 RTD, 0.1° resolution	-99.9~600.0 °C; -99.9~999.9 °F	
P100	P100	PT100 RTD, 1° resolution	-200~600 °C; -320~1100 °F	
Cu50	Cu50	CU50 RTD	-50.0~150.0 °C; -60~300 °F	

### Note 2. Outy - Control output mode

- 0: Set J1 relay as alarm output, SSR output disabled.
- 1: Set J1 relay as PID control output, SSR output disabled. SV is the control temperature.
- 2: Set J1 relay as alarm output, set SSR as PID control output. SV is the control temperature.

- 3: Set J1 relay as alarm output, set SSR as on/off control output. SV is the control temperature.
4. Set J1 relay as on/off control output, SSR output disabled.

### Note 3. Hy - Hysteresis Band

The parameter Hy is only for on/off control. For heating control mode, when the measured temperature PV reaches the target temperature **SV**, the control output will be off; when PV drops down to **SV-Hy**, the control output will be on again. For cooling control mode, when PV drops down to SV, the control output will be off, when PV increases to **SV+Hy**, the control output will be on again.

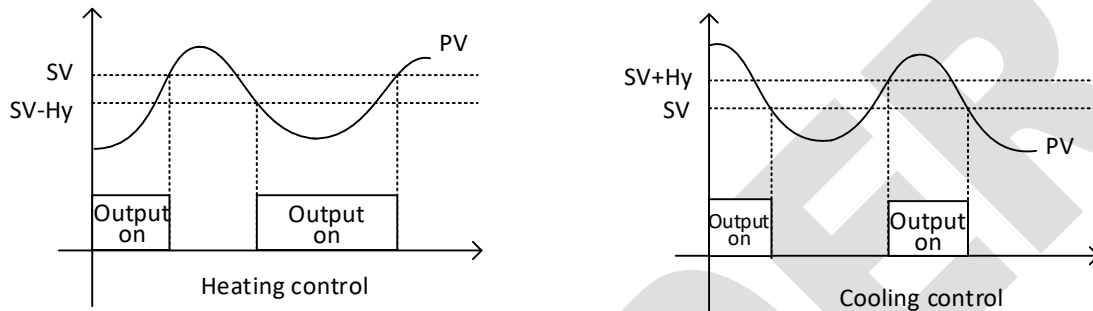

Figure 4. on/off control

### Note 4. PSb - Display temperature offset

This feature allows the input value to be changed to agree with an external reference or to compensate for sensor error. For example, if the measured temperature of the controller is 100 degrees, but the reference temperature is 98 degrees. By setting the **PSb**= -2, the PV display of the controller would change to be 98. To set the negative value for **PSb**, use the > key to move the focus digit to the first digit from the left, then use the down key to change the digit to show the negative symbol.

## 7 PID parameters (input passcode 0036 after pressing the SET key)

Table 3

Symbol	Name	Description	Range	Factory value	Mark
<i>P</i>	P	Proportional band	0.1~99.9%	5.0	<a href="#">Note 5</a>
<i>I</i>	I	Integral time	2~1999 Seconds	100	<a href="#">Note 6</a>
<i>d</i>	d	Derivative time	0~399 Seconds	20	<a href="#">Note 7</a>
<i>SouF</i>	SouF	Overshoot suppression factor	0.0~1.0	0.2	<a href="#">Note 8</a>
<i>ot</i>	ot	Proportional cycle	2~199 seconds	2	<a href="#">Note 9</a>
<i>FiLt</i>	FiLt	Digital filter factor	0~3	0	<a href="#">Note 10</a>
<i>End</i>	END	Exit			

### Note 5. P – Proportional band

The proportional term produces an output value that is proportional to the current error value. A high proportional gain results in a large change in the output for a given change in the error. If the proportional gain is too high, the system can become unstable. In contrast, a small gain results in a small output response to a large input error, and a less responsive or less sensitive controller. If the proportional gain is too low, the control action may be too small when responding to system disturbances. In a real system, proportional-only control will leave an offset error in the final steady-state condition. Integral action is required to eliminate this error.

**Note 6. I – Integral time**

The contribution from the integral term is proportional to both the magnitude of the error and the duration of the error. The integral in a PID controller is the sum of the instantaneous error over time and gives the accumulated offset that should have been corrected previously. The accumulated error is then multiplied by the integral gain and added to the controller output. The integral term accelerates the movement of the process towards set point and eliminates the residual steady-state error that occurs with a pure proportional controller. However, since the integral term responds to accumulated errors from the past, it can cause the present value to overshoot the set point value.

**Note 7. d – Derivation time**

The derivative of the process error is calculated by determining the slope of the error over time and multiplying this rate of change by the derivative gain. The magnitude of the contribution of the derivative term to the overall control action is termed the derivative gain. Derivative action predicts system behavior and thus improves settling time and stability of the system. An ideal derivative is not causal, so that implementations of PID controllers include an additional low pass filtering for the derivative term, to limit the high frequency gain and noise. Normally **d** is set to 25% of the **I** value.

**Note 8. SouF – Overshoot suppression factor**

Overshooting and undershooting are restricted by the **Souf** and increase of the parameter can suppress the overshooting.

**Note 9. ot – Proportional cycle**

It is the cycle time to switch the output on/off. Within the cycle **t** time, the output will turn on and off once. For SSR, in general the cycle time is set to 2 seconds. For mechanical relays, set the cycle time to a higher value (for example, 5~60 seconds) to save the lifetime of the relay.

**Note 10. Filt – digital filter factor**

The filter is to increase the measured temperature display stability, but will delay the response. When **Filt** is set to 0, the filter is disabled. 1, 2 and 3 are weak, medium and strong, respectively.

## 8 Auto tune

For PID control mode, if the control with default **P**, **I** and **d** parameters settings are not able to hold the target temperature, the built-in auto tune function can find the right PID parameters for the system automatically. When on heating mode, it will heat up the system to the target temperature then let the system cool down. It will repeat this process for about 3 times, then the controller will calculate the parameters.

To activate the auto tune function, press and hold the **>** key until the “AT” indicator starts to blink. When auto tune process finished, the “AT” indicator will stop blinking. The new values for parameters **P**, **I** and **d** are calculated by the controller.

To stop the auto-tuning, press and hold **>** key for 3 seconds, until “AT” indicator stops blinking. The PID parameters values will not change.

Please note:

- Auto tune from time to time, there could be a significant temperature overshoot, if so, please lower **SV** value to prevent accident.
- The sensor, load (heater...) need to be connected properly, otherwise, the auto tune will not complete.

- The time for the auto tune depends on the system response time, would be from a few minutes to hours.
- Only need to run auto tune one time.

## 9 SV and alarm parameters (input passcode 0001 after pressing the SET key)

Table 4.

Symbol	Name	Description	Factory value	Mark
$S_v$	SV	Target temperature (Set Value)	80	<a href="#">Note 11</a>
$AH1$	AH1	Alarm (J1 relay) on temperature	800	<a href="#">Note 12</a>
$AL1$	AL1	Alarm (J1 relay) off temperature	900	
$E_{nd}$	END	Exit		

**Note 11.** The SV value can be set by accessing the 0001 menu. Or, when in normal operation mode, use the **UP** or **DOWN** key to change the **SV** directly.

**Note 12.** When the J1 relay is set as alarm, the relay will be controlled by the two parameters **AH1** and **AL1**. The alarm can be set as either high limit alarm or low limit alarm.

For high alarm, set **AH1 > AL1**. When the temperature increase to **AH1**, the J1 relay will be closed (alarm on), when the temperature drops down to **AL1**, the J1 relay will be open (alarm off).

For low alarm, set **AH1 < AL1**. When the temperature decrease to **AH1**, the J1 relay will be closed (alarm on), when the temperature increases to **AL1**, the J1 relay will be open (alarm off).

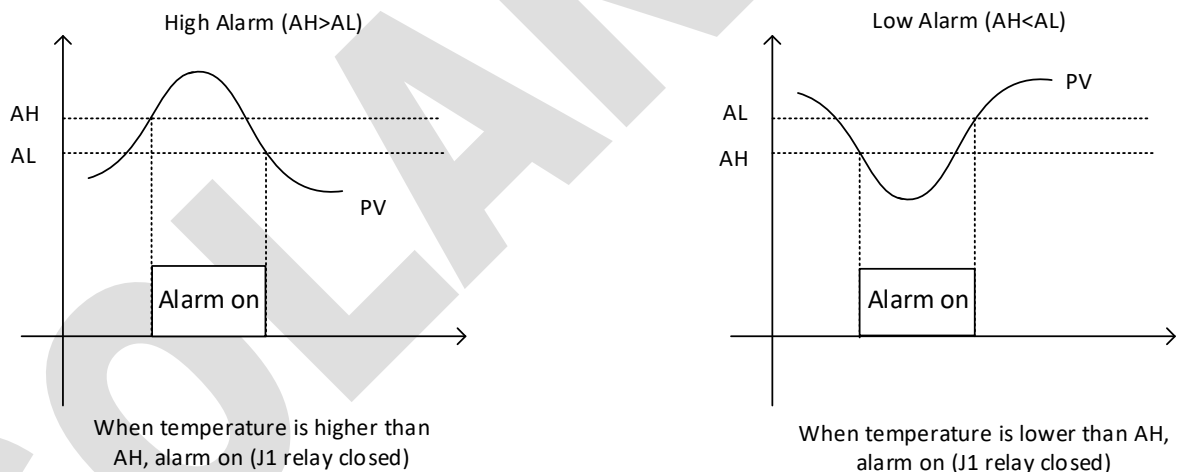

Figure 5. High/Low alarm

## 10 Examples

### 10.1 Control a 110V Heater via SSR

Use SSR, thermocouple to work with the controller to hold the temperature at 700°F. Please see [Figure 6](#) for wiring diagram.

Parameter setting: SV=700. Keep default settings for all the other parameters.



**Note:** For 220V heater, change the AC power source to 220V AC, use hot line 1 (L1) and hot line 2 (L2) to power it.

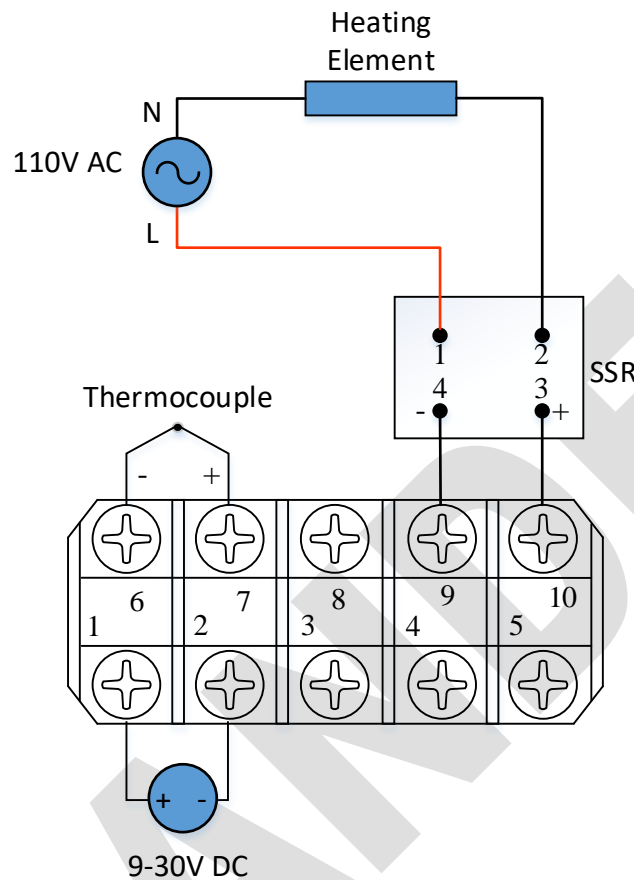

Figure 6. SSR Wiring Diagram

## 10.2 Control a 12V DC Solenoid Valve

Use PT100 probe to work with 12V DC solenoid valve. Please see [Figure 7](#) for wiring diagram.

- 1) To use PID mode to control the valve, set outy=1, set cycle time ot=15 seconds to save the lifetime of the J1 relay and the valve. Set the SV to the desired temperature you want to hold, for example, SV=350°F.
- 2) To keep the temperature in a range, for example, 330-350°F, set the output control to on/off mode, outy=4; keep the cycle time setting ot=2. Set SV=350, Hy=20. The output will be off when temperature goes above 350°F, and will be on again when temperature drops down to SV-Hy=320°F.



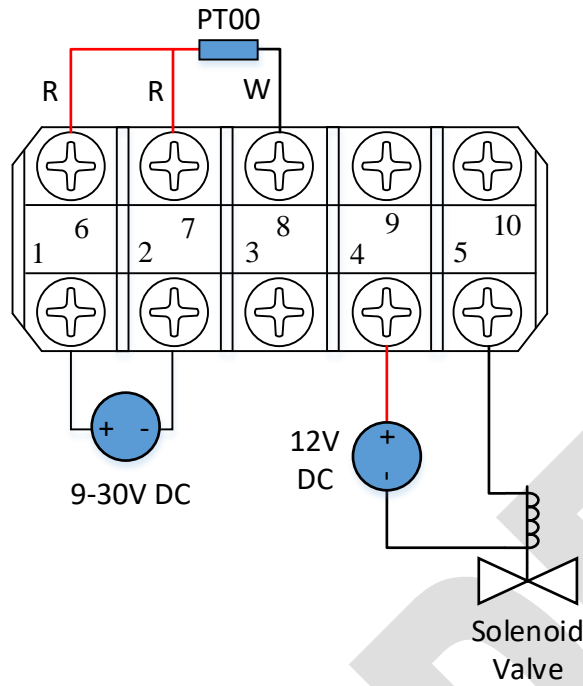

Figure 7. Solenoid Valve Wiring

### 10.3 Control a 220V AC Heater via Contactor

If heater draws more than 3A, the J1 relay could not handle it directly. A 220V coil contactor can be used to power the heater.

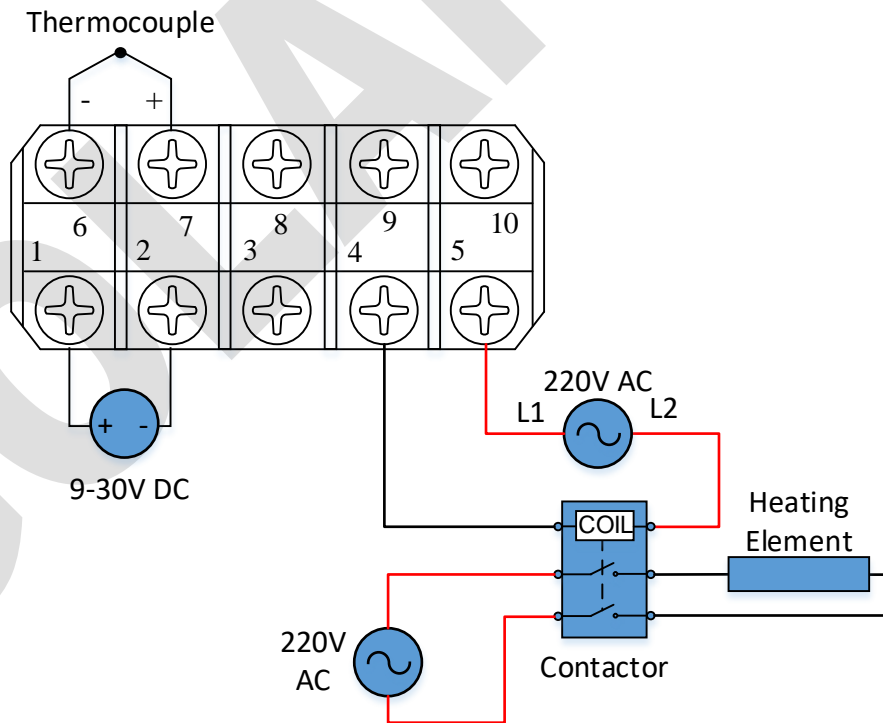

Figure 8. Use Contactor for Heater

- 1) To use PID mode to control the heater, set outy=1, set cycle time ot=15 seconds to save the lifetime of the J1 relay and contactor. Set the SV to the desired temperature you want to hold, for example, SV=350°F.

- 2) To keep the temperature in a range, for example, 330-350°F, set the output control to on/off mode, **outy**=4; keep the cycle time setting **ot**=2. Set **SV**=350, **Hy**=20. The output will be off when temperature goes above 350°F, and will be on again when temperature drops down to **SV**-**Hy**=320°F.

#### 10.4 Use J1 Relay to Trigger a 12V Alarm Buzzer

J1 relay is controlled by parameters **AH1** and **AL1** when J1 is set to alarm output (**outy**=0, 2 or 3).

- 1) High alarm: If you want the buzzer to be on when temperature is higher than 210°F, and to be off when temperature drops down to 205°F, set **AH1**=210, **AL1**=205 (**AH**>**AL**).
- 2) Low alarm: If you want the buzzer to be on when temperature is lower than 5°F, and to be off when temperature goes back to 10°F, set **AH1**=5, **AL1**=10 (**AH**<**AL**).

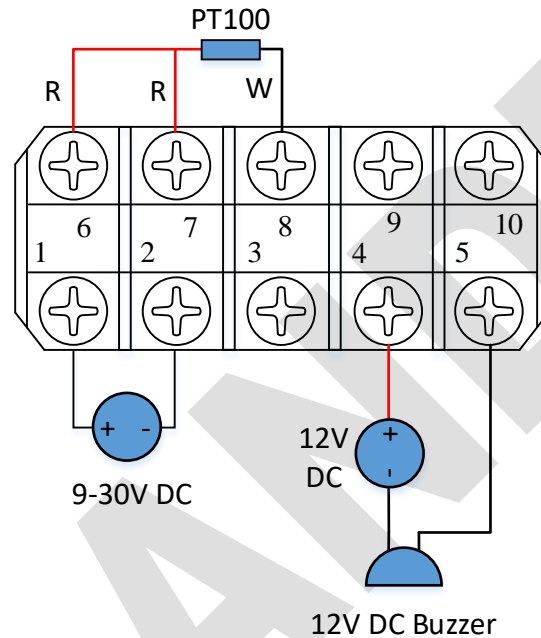

Figure 9. Use J1 Relay for Alarm

## 11 Quick Guide

First, set the parameter **Inty** to the sensor type connected to the controller if it is not a K type thermocouple, set the parameter **Outy** for the output control mode. For controlling a mechanical relay in PID mode, change the cycle time **ot** to 5~60 seconds to save the lifetime of the relay. Then you are ready to go. For PID mode, if the system is not able to hold the temperature, run [Auto tune](#). Set the alarm parameters **AH**, **AL** if needed.

If the controller displays EEEE, that means something wrong with the input or with the setting of the input. Please check the sensor connection and the **Inty** parameter setting. Questions? Please contact us.

Golander LLC  
<http://golanderusa.com>  
 email: [info@golanderusa.com](mailto:info@golanderusa.com)